

# COMPANY PROFILE

MOTION CONTROL SOLUTIONS FOR YOUR EVERY NEED



**“There is no substitution when it comes to high quality”**

-Dave Cawood (Founder / Managing Director)

# COMPANY OVERVIEW



Since 2010, DC Auto-Motion (Pty) Ltd has been a trusted supplier of world-class motion control components across South Africa and beyond. We're the preferred partner for OEMs, resellers, and system integrators seeking performance, durability, and expert support.

DC Auto-Motion (Pty) Ltd represent industry leaders such as THK, MiniTec, Kübler, Güdel, Zimmer Group, NBK, Wörner, IBC and Nippon Bearings - offering precision-engineered solutions from linear guides to rotary encoders, coupling systems to complete automation platforms.

Our clients span automotive, industrial, mechanical, packaging and electrical sectors. Whether you're upgrading a legacy system or launching a cutting edge automation project. our local team delivers the technical insight and hands-on support to keep your operation moving.





# COMPANY TIMELINE

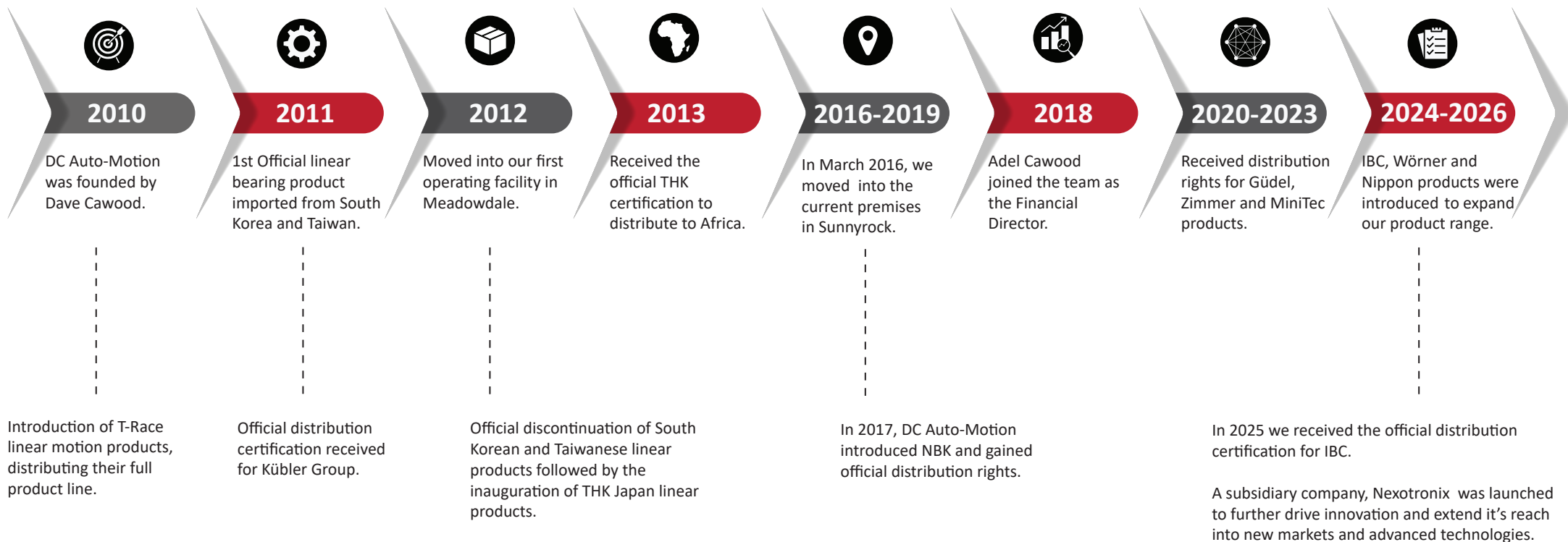



# OUR PRODUCTS

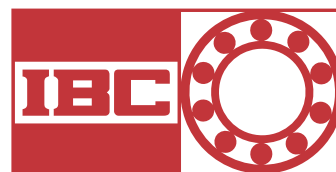



## DC Auto-Motion is the official distributor of THK products for Africa.

THK's linear motion system enables rapid improvements in accuracy, speed and labour-saving potential of advanced mechatronic instruments. THK became the first company in the world to develop and commercialize the Linear Motion (LM) Guide.

### PRODUCTS WE OFFER:

- CAGED BALL LM GUIDES
- STANDARD LM GUIDES
- LM BUSHINGS AND LM SHAFTS
- PRECISION/ROLLED BALL SCREWS
- LEAD SCREWS
- PRECISION BALL SPLINES
- PRECISION CROSS ROLLER RINGS
- CROSS ROLLER GUIDES
- LM STROKE
- LM ACTUATORS
- CAM FOLLOWERS
- GREASE LUBRICANTS

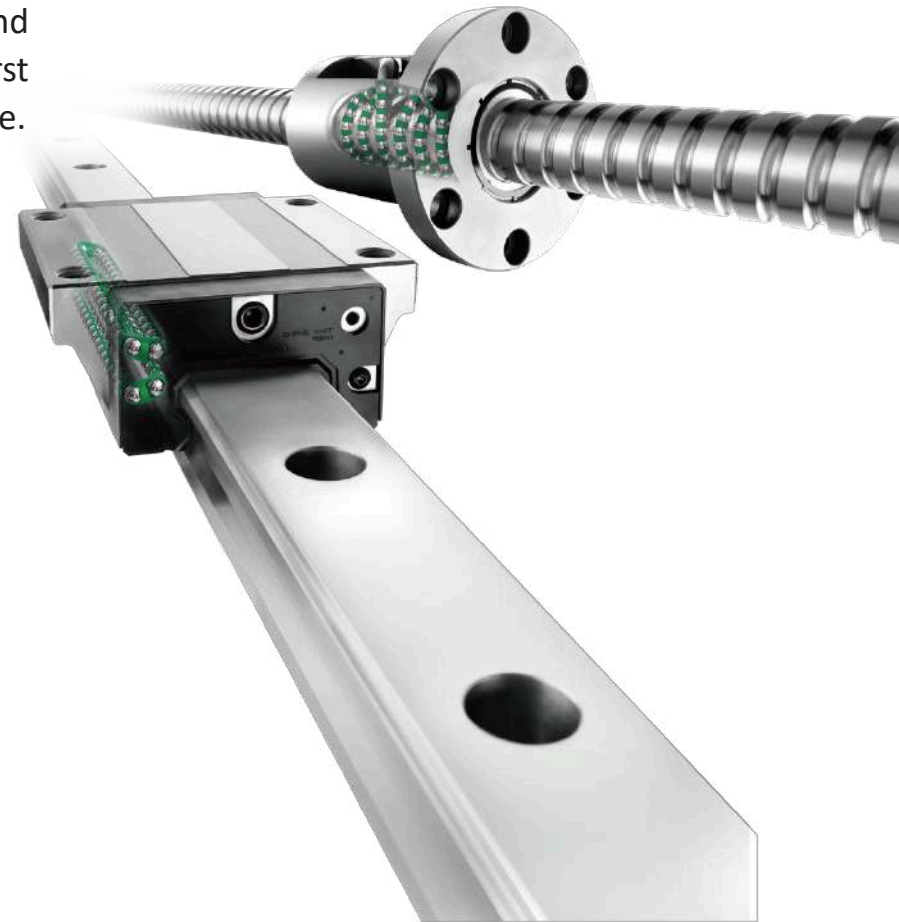

# MiniTec

THE ART OF SIMPLICITY

MiniTec's T-Slot profile system enables quick, tool-free construction of workstations, machine frames, guards, and conveyor structures. The patented Powerlock fastening system means no drilling, no tapping - just strong, reconfigurable structures fast.

## PRODUCTS WE OFFER:

- PROTECTION SYSTEMS
- CONVEYOR TECHNOLOGY
- WORKPLACE SYSTEMS
- PROFILE SYSTEMS
- LINEAR SYSTEMS

DC Auto-Motion is the official distributor of MiniTec products for Africa



**DC Auto-Motion is the official distributor of Fritz Kübler products for Africa.**

Fritz Kübler is the leading specialist of position and motion sensors worldwide, and offers individually tailored product and sector solutions, as well as solutions for Functional Safety.

**PRODUCTS WE OFFER:**

- ROTARY ENCODERS
- SLIPRINGS
- COUNTERS
- DRAWWIRES



# GÜDEL

**DC Auto-Motion is the official distributor of Güdel products for Africa.**

Güdel is a global leader in linear motion modules, gantry systems, and gear components for demanding automation. With 70+ years of engineering expertise, their solutions are trusted in automotive, logistics, aerospace, and heavy industries.

## **PRODUCTS WE OFFER:**

- RACK AND PINIONS
- GEARBOXES
- LINEAR GUIDES

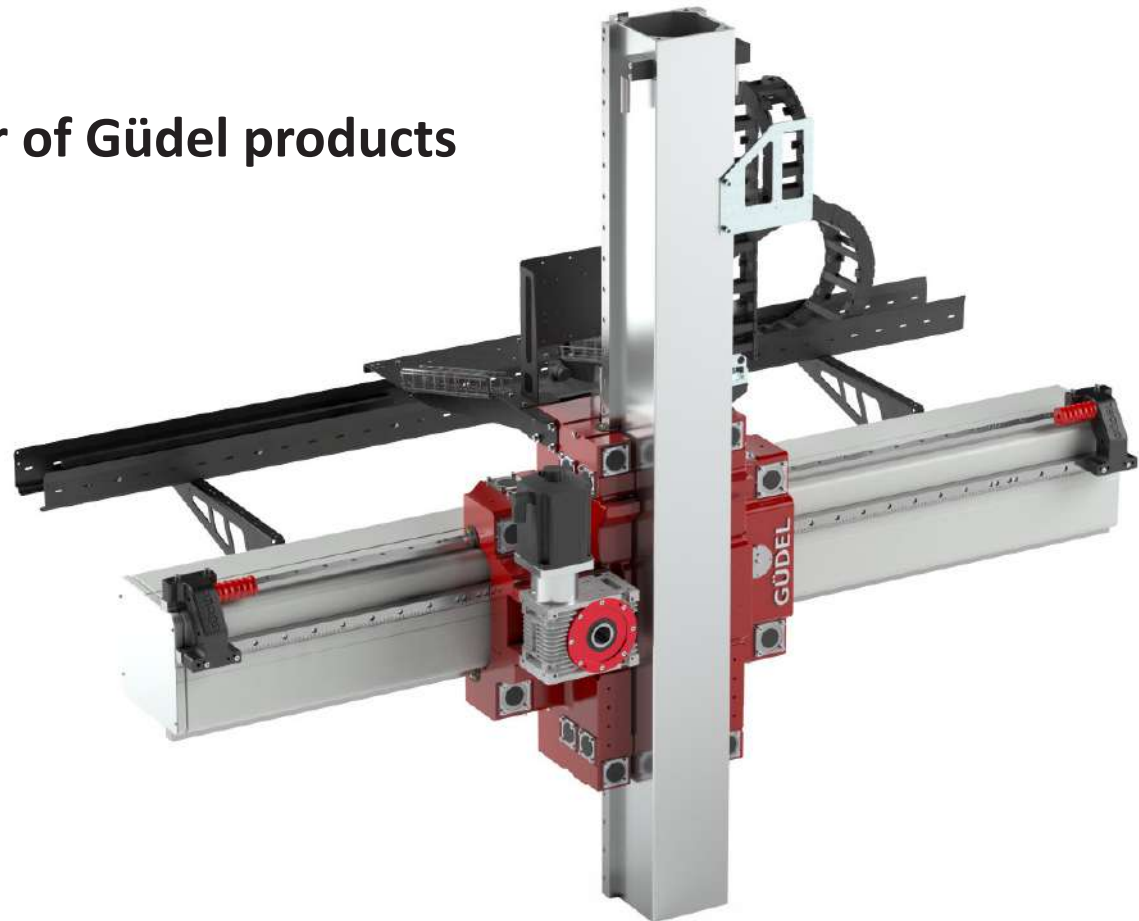



**DC Auto-Motion is the official distributor of Zimmer products for Africa.**

Zimmer Group's automation solutions captivate with precision and versatility. Their extensive range, including over 2000 standardised grippers, swivel units, and robotic accessories, ensure robust performance across industries

**PRODUCTS WE OFFER:**

- LINEAR TECHNOLOGY
- HANDLING TECHNOLOGY
- DAMPING TECHNOLOGY
- MACHINE TOOLING TECHNOLOGY
- ROBOTIC TECHNOLOGY
- SYSTEM TECHNOLOGY AND APPLICATION





**DC Auto-Motion is the official distributor of NBK products for Africa.**

NBK products are used in advanced industries, such as manufacturing equipment for semiconductors, robotics, machine tools and medical devices.

**PRODUCTS WE OFFER:**

- SPECIAL SCREWS
- MACHINE ELEMENTS
- COUPLINGS



# Wörner

Wörner's mechanical modules are designed to bring consistency, speed, and reliability to automated motion. Whether stopping, indexing, lifting, or damping, each unit is built to protect downstream systems, enhance accuracy, and optimise layout space.

## PRODUCTS WE OFFER:

- SEPARATING STOPS
- ROLLER STOPS
- ANGLE DAMPERS
- INDEX CYLINDERS
- ANTI-BOUNCE STOPS





**DC Auto-Motion is the official distributor of IBC products for Africa.**

IBC's linear motion technologies are engineered to deliver smooth, low-friction travel in space-constrained applications.

**PRODUCTS WE OFFER:**

- ECO-Runner Guides
- TELESCOPIC-Runners
- Easy Runner Bearings
- FLEXY-Runner Curve Guides
- INOX-Runner Stainless Steel Systems
- Displacement Stops





## NIPPON BEARING

Nippon Bearing (NB) is a pioneer in linear motion technology, recognised for precision Japanese engineering. Their Slide Bush and TOPBALL ranges are the industry standards for applications requiring smooth, high-speed, and high-accuracy linear travel.

### PRODUCTS WE OFFER:

- LINEAR BUSHING
- TOP BALL

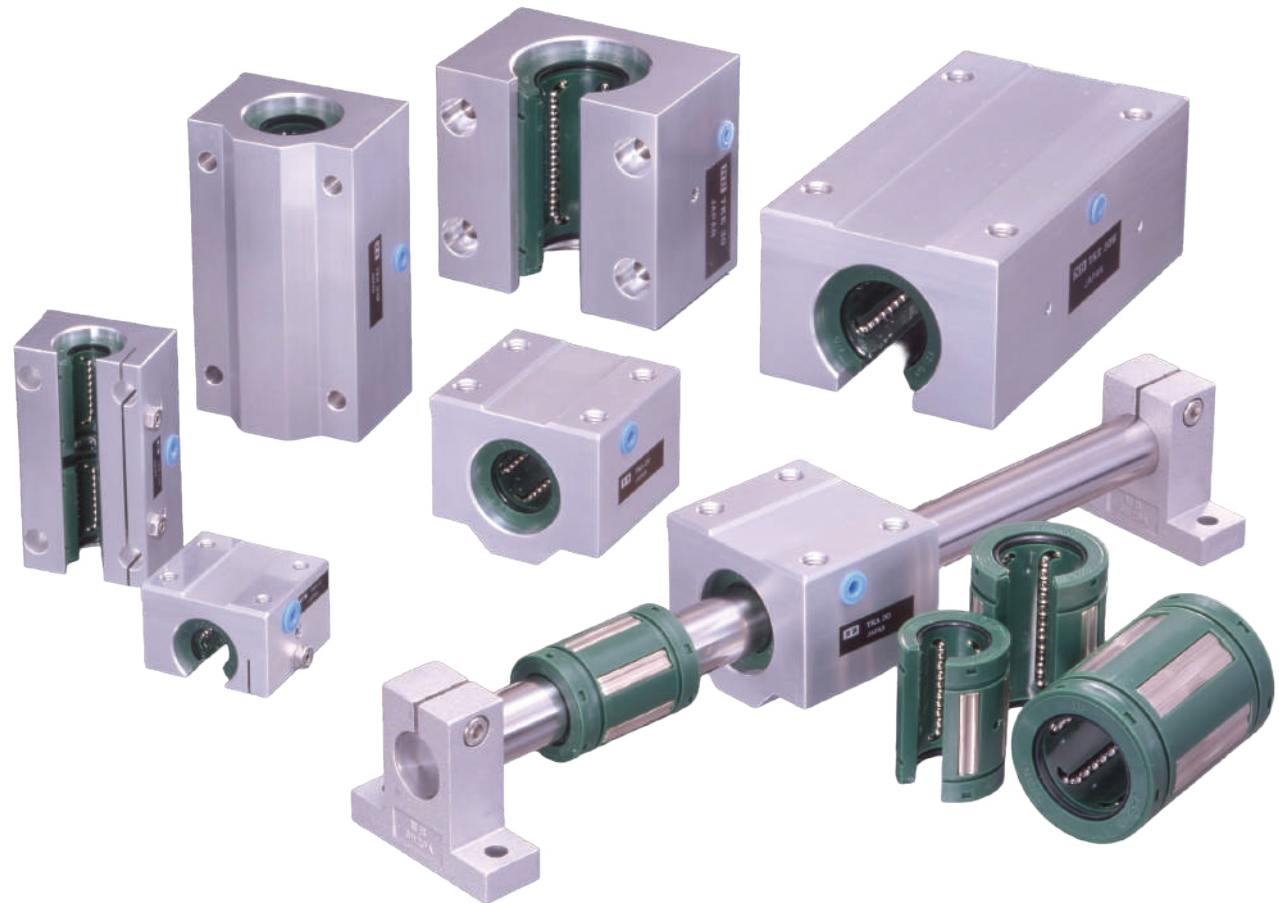



**11 Sunrock Close, Sunnyrock Ext 2,  
Germiston, Gauteng, South Africa**



**+27 (0) 11 453 1740**



**Contact@dcauto-motion.co.za**

**“There is no substitution when it  
comes to high quality”**

**-Dave Cawood (Founder / Managing Director)**

**www.dcauto-motion.co.za**